

PREPARATION

The following section is designed to give guidance on the installation & maintenance of Marlin PVC-U windows & doors.

The procedures in the BPF Code of practice for The Installation of PVC-U Windows and Door Sets (Ref 362/2, or any subsequent updates), should be followed.

Pre-Start Check

Check the survey and goods

Prior to starting any work the installer should check the following :-

- The survey sheets are correct and clear
- The types of windows supplied are correct to the **customers order** and are **undamaged**.
- **Glass** type and pattern are correct.
- **Window** and **glass sizes** are compatible.
- All cills, trims and gaskets are correct.

Care of property

The **installer is responsible** for both internal and external protection.

Check for both internal and external defects in the structure. Any found should be checked with the surveyor.

Any furniture and fittings should be moved away from the working area.

Carpets and soft furnishings should be covered with clean dust sheets.

All access areas should be covered with dust sheets.

Check the windows are **not load-bearing**. Ensure there is a lintel or suitable load-transferring structure above the window.

Removal of existing windows

Flat windows

Damage will inevitably be caused to the adjacent reveals but care must be taken to keep this to a minimum.

Score around the internal perimeter to minimise damage to plaster and decorations.

Remove any trims and cover fillets.

Remove all opening lights.

Remove fixed light glass carefully to avoid injury.

Cut through and remove transoms and mullions.

Saw through the jambs and remove them taking care not to damage internal cills. Remove heads and cills in the same way.

If a new internal cill is to be fitted, remove the existing cill at the same time.

Load-bearing bays

If a replacement bay window is load-bearing, the advice of a structural engineer must be sought prior to the removal of the existing window assembly. The spectus load bearing bay assembly may be used.

Bay windows

When removing bay windows **temporary supports will be required** e.g. Acrow Props or similar. Care must be taken on the position of the props which should support the superstructure without causing damage. Internal and external supports may be necessary.

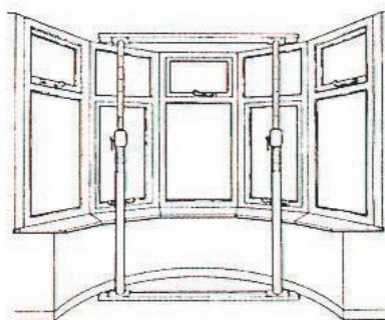

When the superstructure is supported, the window should be removed so as to cause minimum disturbance.

It is recommended that the load-bearing poles are removed one at a time and temporary supports are monitored for any movement.

Any trims removed should be replaced using the appropriate finishing trims

PREPARATION

Existing opening preparation

Before installing the window, the opening should be cleaned of all loose material, fillers or mastic.

Check the existing DPC is not damaged. If non-existent then install one in accordance with the recommendations in the BPF Code of Practice for the Installation of PVC-U Windows and Door Sets (Ref 362/2), or any subsequent updates.

Damage caused by removal of windows should be repaired at the installers expense.

Defects noted during survey should be rectified as agreed at the time of survey.

New build opening preparation

The aperture should be completed before fitting the windows. Windows should not be used as a template for building. The Spectus Former may be used as a template.

Frame preparation

If stacking packers are required they should be fitted before the cills.

If cills are required, there are two methods of fixing:

Cill to building first

The cill is positioned in the aperture and levelled. It is bedded on either a sealant or mortar bed.

A run of sealant is applied to the cill and across the ends before the window is fitted (see below)

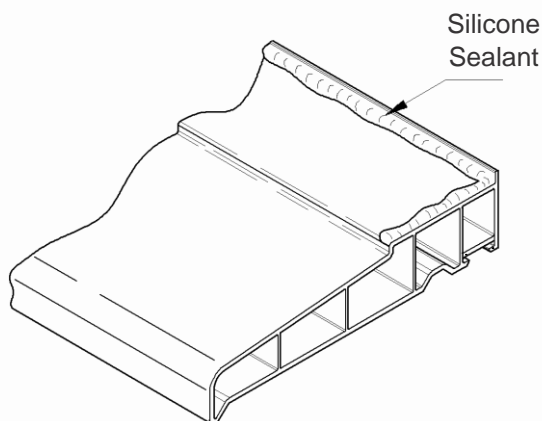

Cill to frame

The cill is cut to length (including the horns if required).

A run of sealant is applied on the frame (see below)

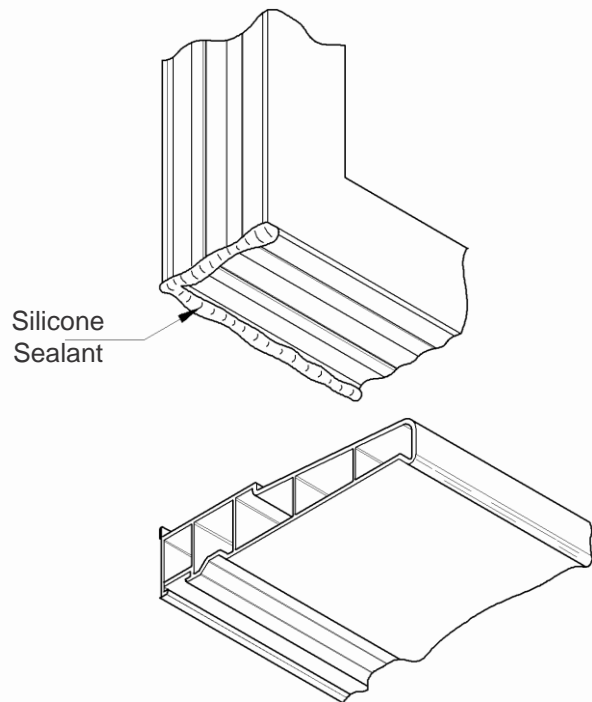

The cill is fitted using self-drilling screws (see below)

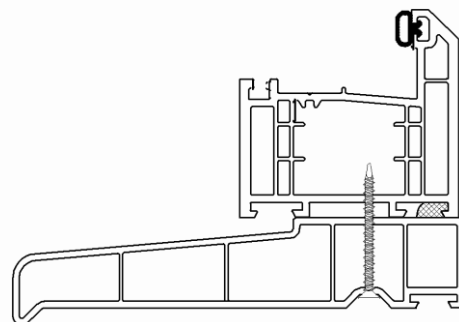

Fit the screws 150mm from the corners and at 300mm centres. Avoid screwing at the mullions.

Fit the cill end caps.

INSTALLATION

Position of window

On large contracts, agreement on window position should be reached before the start of any work.

The position should in general:

- bridge the cavity by a minimum of 30mm
- cover the DPC
- be set back a minimum of 10mm in the opening

When replacing narrow windows (e.g. steel windows) with PVC-U, it is necessary either to cut back the plaster or to fit odd legs to the frame to ensure the outside face of the window is set back from the building line.

Sequence

Make sure that the frame is square and true and not distorted.

Temporarily wedge the window in place.

Check the opening lights operate and do not foul the surrounds.

Methods of fixing

There are various methods of fixing available which may be used separately or in combination:

Through frame fixing

There are many types of suitable screws and plugs. The frame should be drilled and the inner face opened up to 13mm to allow cover caps to be fitted. The diagram below shows a typical woodscrew and plug fixing.

Through frame fixing

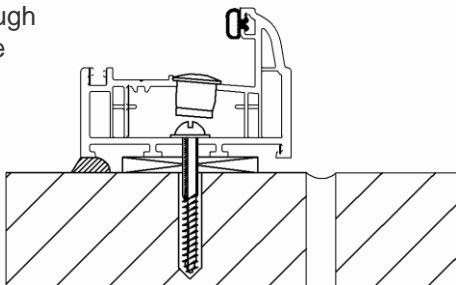

Lug fixing

Where lugs are to be bent to follow the building contours this should be carried out prior to clipping onto the frame to avoid distortion or damage. The following diagram shows a typical lug fixing.

Lug fixing

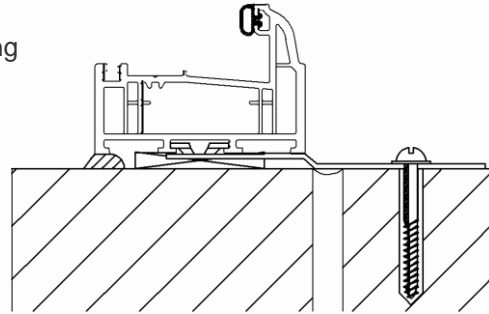

With either method of fixing, all fixings should be of a material and finish to offer high performance corrosion resistance.

Avoid distortion of the frame by using packing shims at the screw positions. The frame should be packed to ensure correct operation of opening lights and so as to not alter overlaps or clearances.

All fixings should penetrate the surrounding substrate by a minimum of 30mm.

All temporary wedges should be removed before the fixings are secured.

Fixing distance

The following general guidelines apply to fixings on all four sides of the frame:

The corner fixing should be a minimum of 150mm and a maximum of 250mm from the corner.

Intermediate fixings should be no greater than 600mm centres.

No fixing should be closer than 150mm, or further than 250mm to the centre line of mullions or transoms

There must be a minimum of 2 fixings on each jamb.

Fixing at cills

In general, fixings at the cill should be in accordance with the rules given in this section. However, when a sub cill is screwed to the cill section of the outer frame, the rules given for head fixings can be followed, providing an adequate silicone or mortar bed is provided.

INSTALLATION

Special Cases

Polyurethane Foam

Experience has shown that fewer problems arise if fixings are used in accordance with page Gen.22. However, the presence of pre-cast concrete or steel lintels may make it impractical or pose severe difficulties in achieving the specified fixing distances. In these circumstances the use of polyurethane foam has proved a useful adjunct to mechanical fixings.

General Guidelines for Bow / Bay Windows

The rules for fixing and installation of flat windows also apply to bays with the following additions:

Site conditions and the size of the bay will determine if the bay is pre-assembled or assembled in situ.

Whichever method is used, checks must be made to ensure no loads are carried by individual segments.

Load bearing bays are no longer covered in the BPF Code of Practice for the Survey and Installation of Windows and External Doorsets (362/2). They will be dealt with in a separate code of practice. (Not available at the time of writing).

Spacing of fixings to the bay pole or post should be as the general guidelines on page Gen.22.

Pre-assembly

If the bay is pre-assembled in the factory or on site prior to fitting, the following points should be followed:

Welded cills should be left oversize to allow for final cutting on site

All fixing centres should be as for flat windows

All joints between frames and cills should be silicone sealed.

Joints between stacking packers/baypole adaptors and frames are siliconed.

Site assembly

Before final fixing of cills, windows should be positioned temporarily to check on the line of the cill and the window in relation to the structure of the building.

Typical bay assemblies

